

Publicado em 01.01.2024

Atualizado em 09.10.2024



Page 2



Page 7



Page 9



MRF

Page 13



Page 18



Page 23



HOOSIER RACING TIRE

Page 26



Page 30



Page 32



Page 33



Page 35

**COOPER DISCOVERER TARMAC DT02 - 225/40R18 -
WET CUTTING PATTERN – PHASE 1**

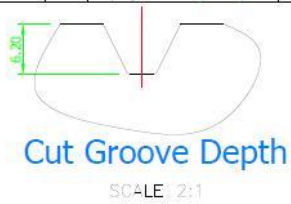

*Green Lines to Be Cut

**COOPER DISCOVERER TARMAC DT02 - 225/40R18 -
WET CUTTING PATTERN – PHASE 2**

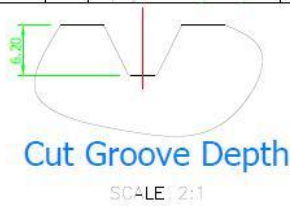
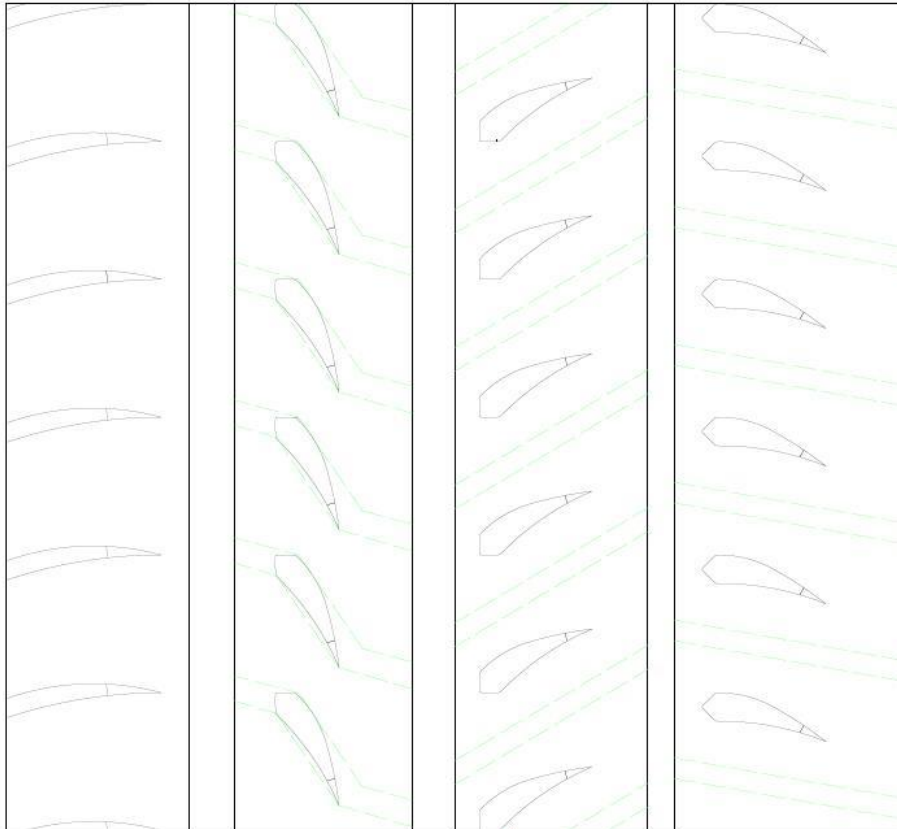

*Green Lines to Be Cut

COOPER DISCOVERER TARMAC DT1 - 205/45R17 - WET CUTTING PATTERN

DRAWING REFERENCES

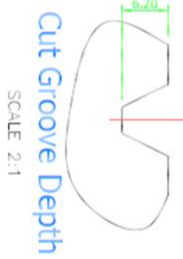

*Green Lines to Be Cut

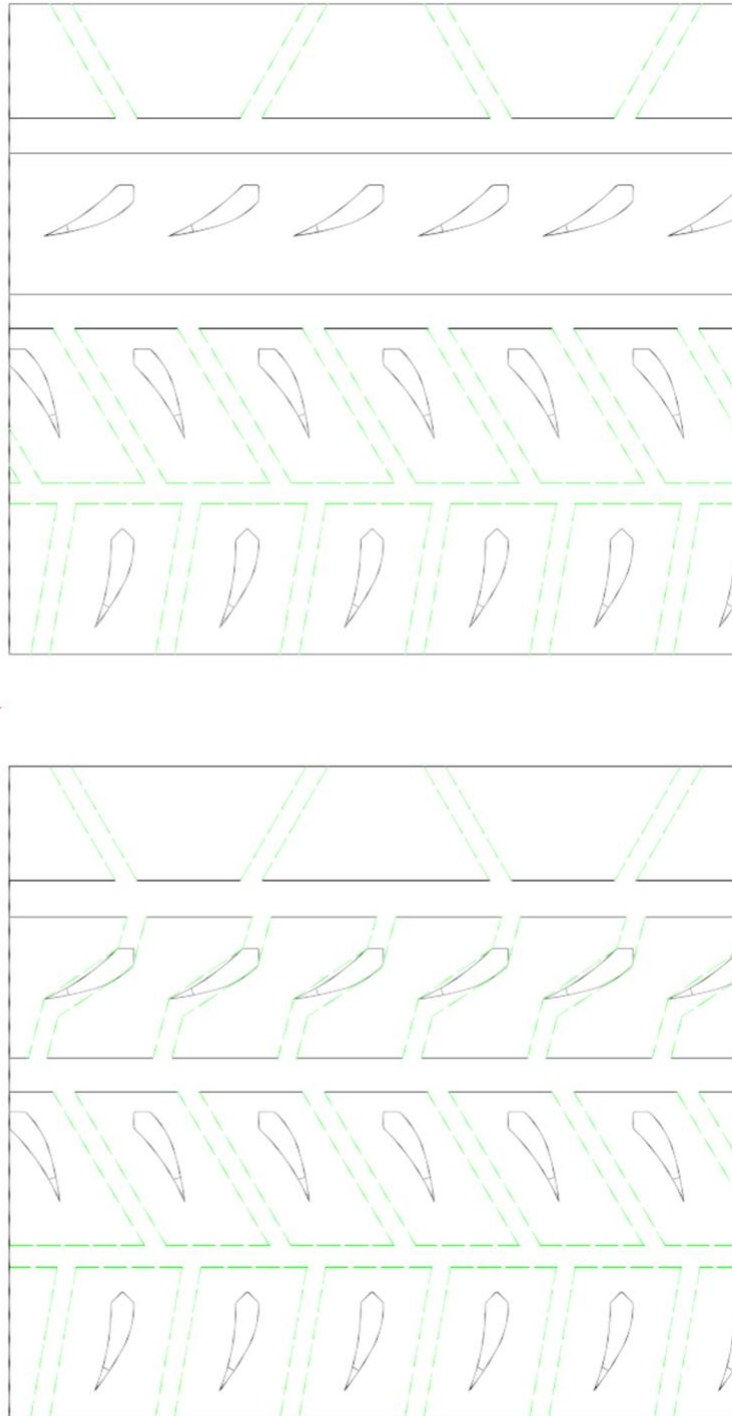

COOPER DISCOVERER TARMAC DT1 - 195/50R16 - WET CUTTING PATTERN

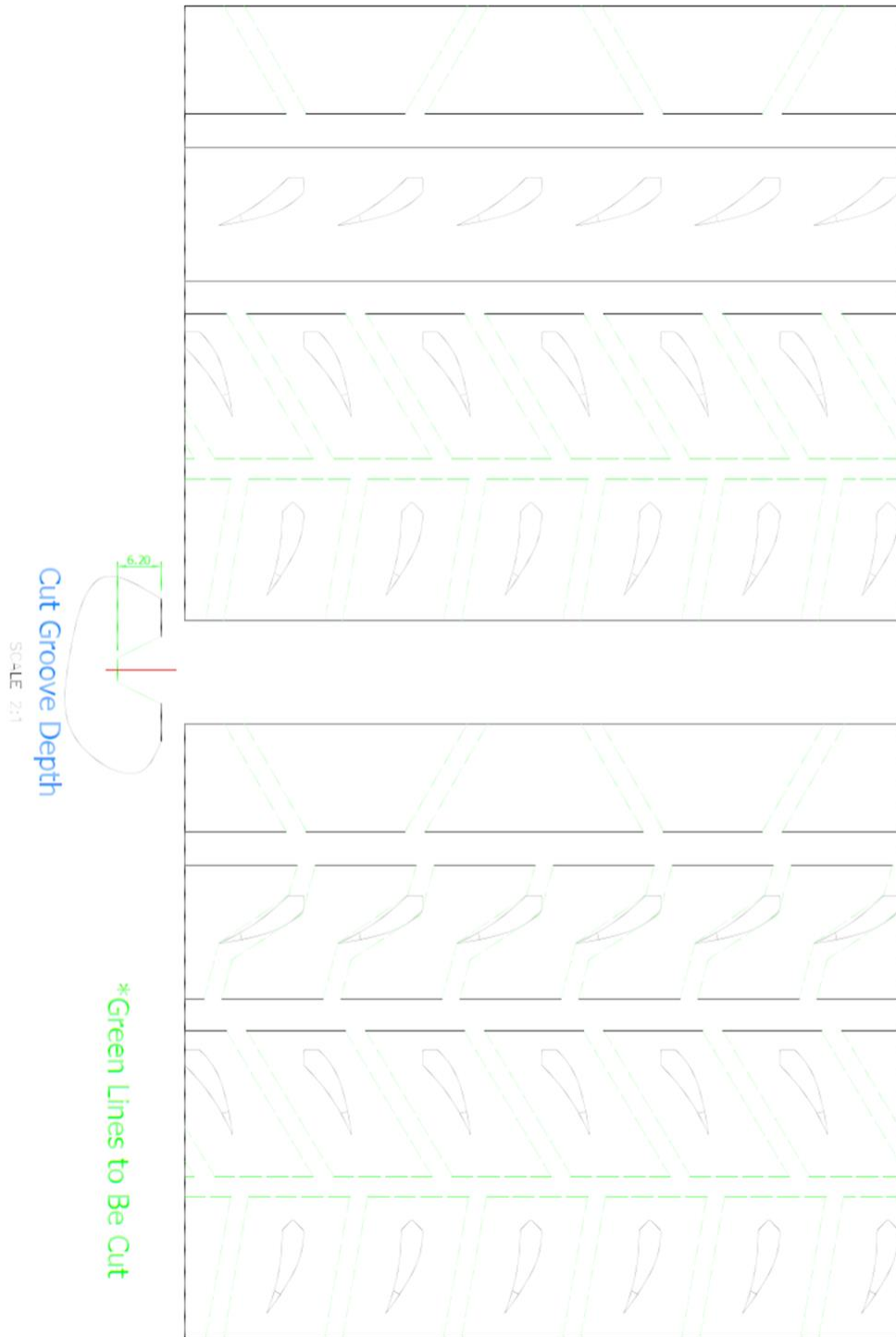

COOPER DISCOVERER TARMAC DT1 - 195/50R15 - WET CUTTING PATTERN

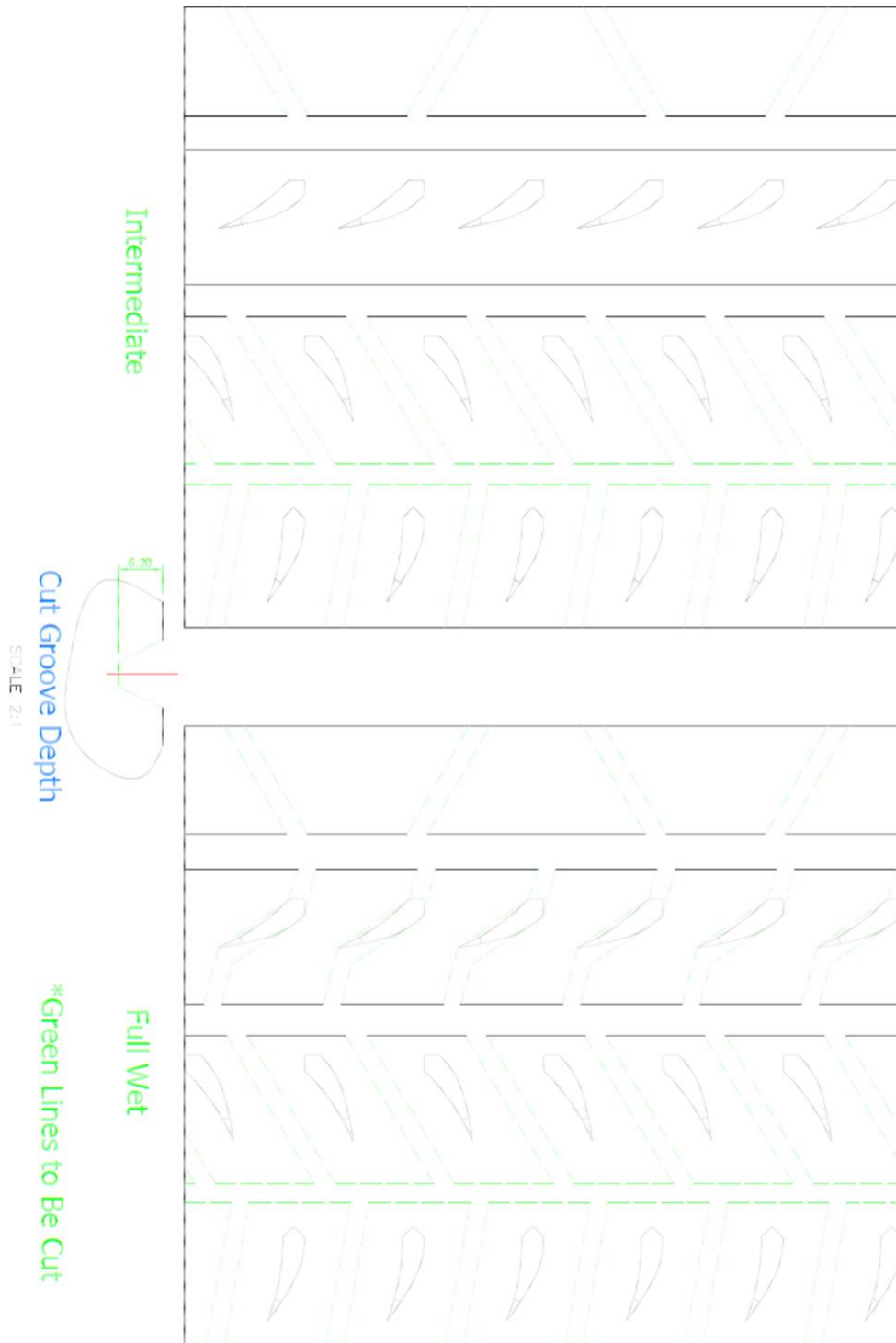

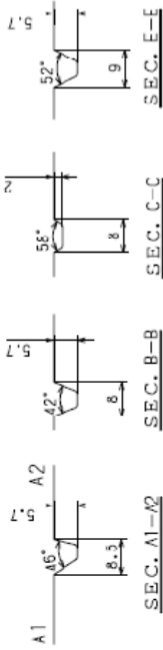

In the control area
5.5mm grooves-18.1%
total grooves-22.2%

----- Control area 170X140

Tyre weight: 9.1kg

HAND-CUT GROOVE RECOMMENDATION

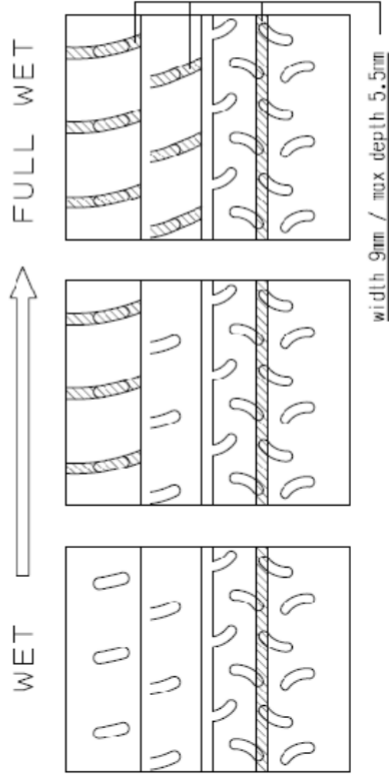

PATTERN NAME
A051A

PRODUCT NAME
YOKOHAMA ADVAN A051T

SIZE 210/650R18

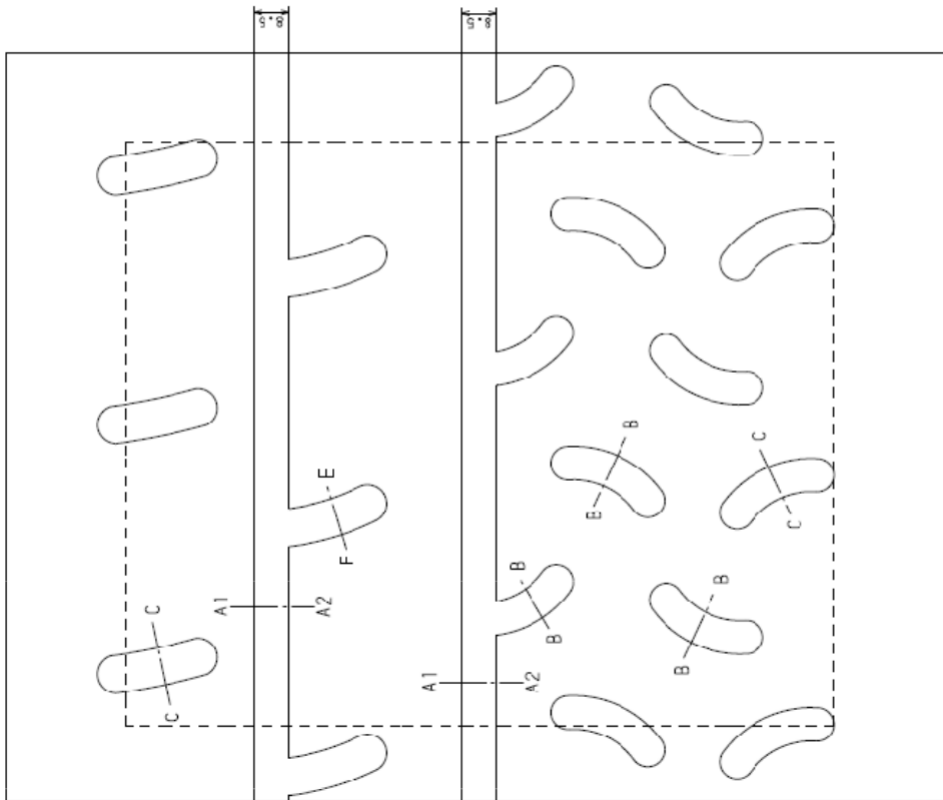

HAND-CUT GROOVE RECOMMENDATION

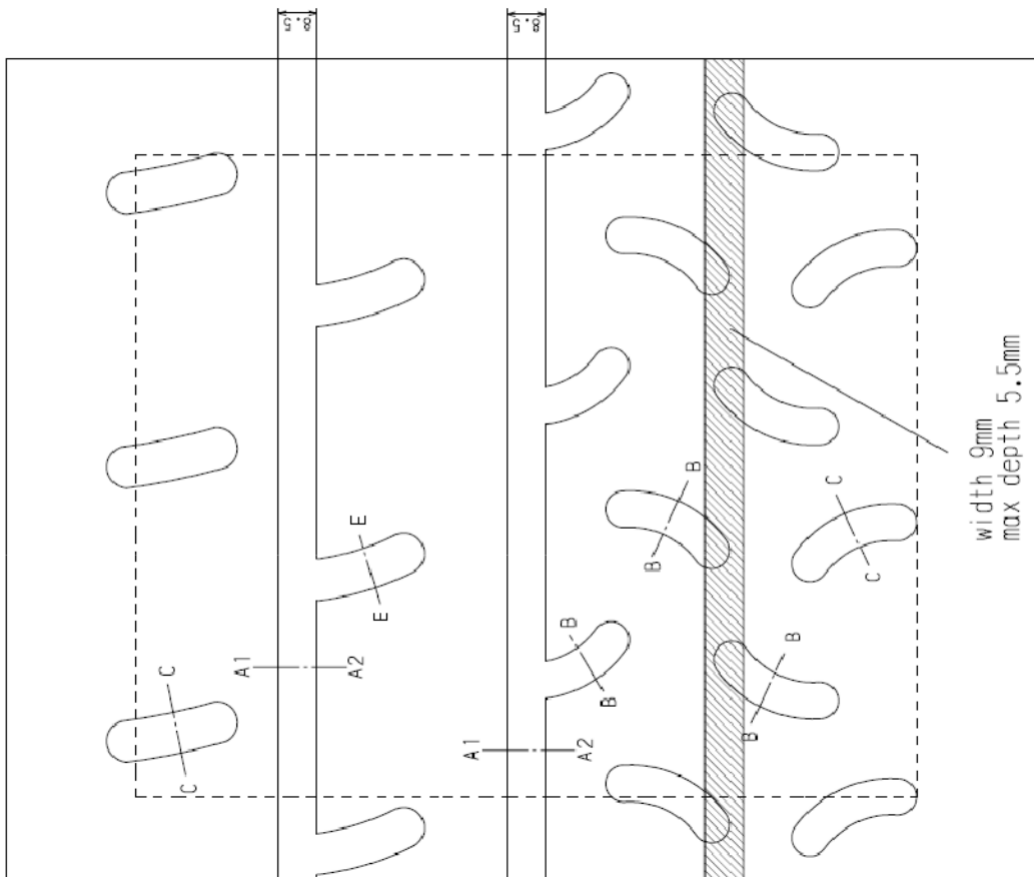
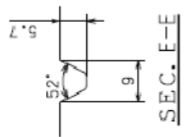
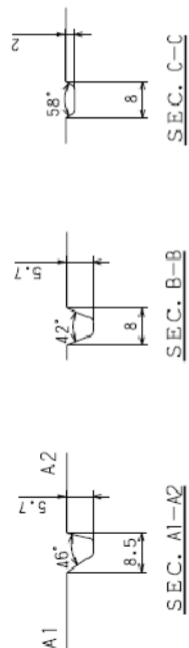

In the control area
5.5mm grooves-18.1%
Total grooves-22.2%

----- Control area 170X140

Tyre weight 9.7kg

PRODUCT NAME
YOKOHAMA ADVAN A051T

PATTERN NAME
A051A

SIZE 210/650R18

DMT RC2

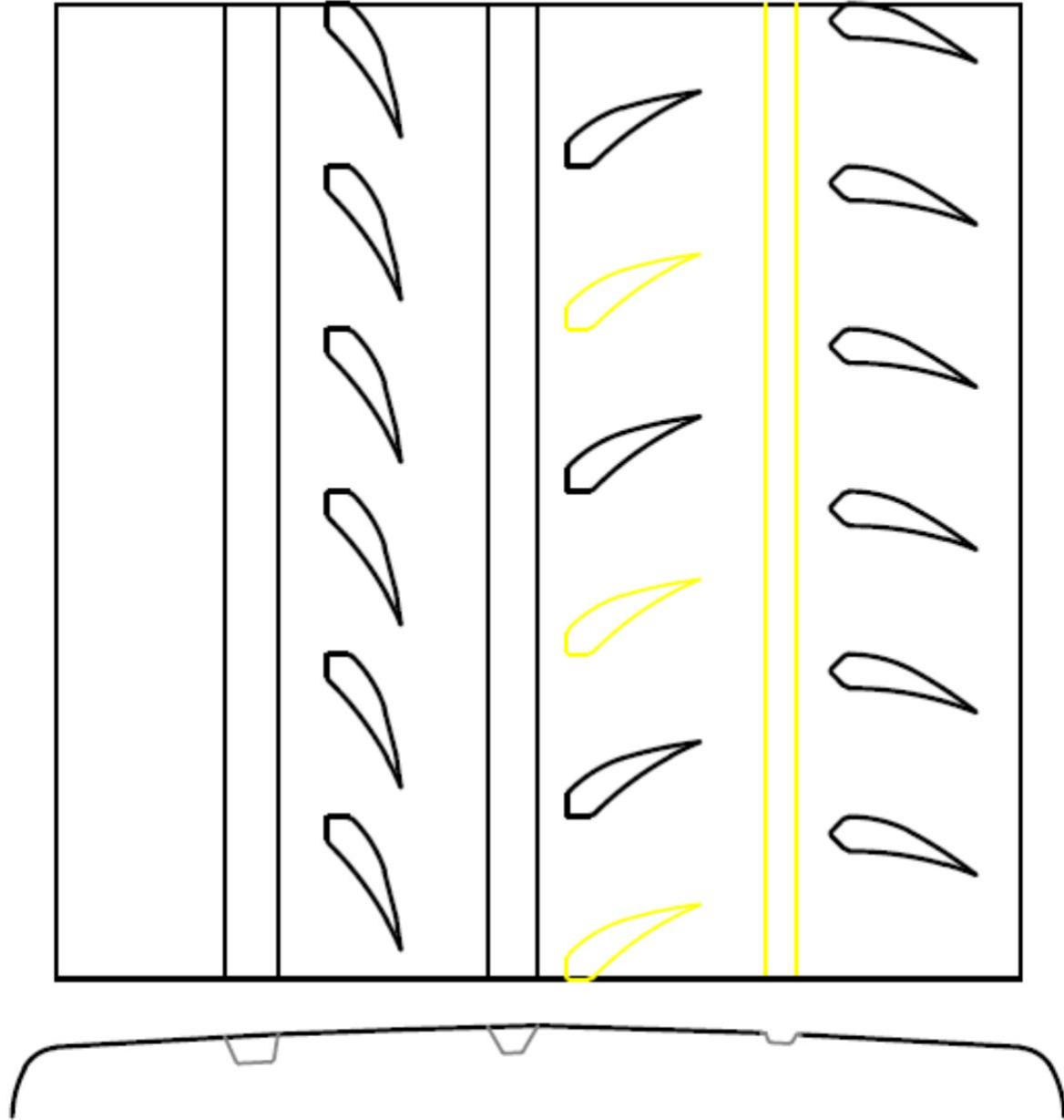

DMT RC2 Wet Cut

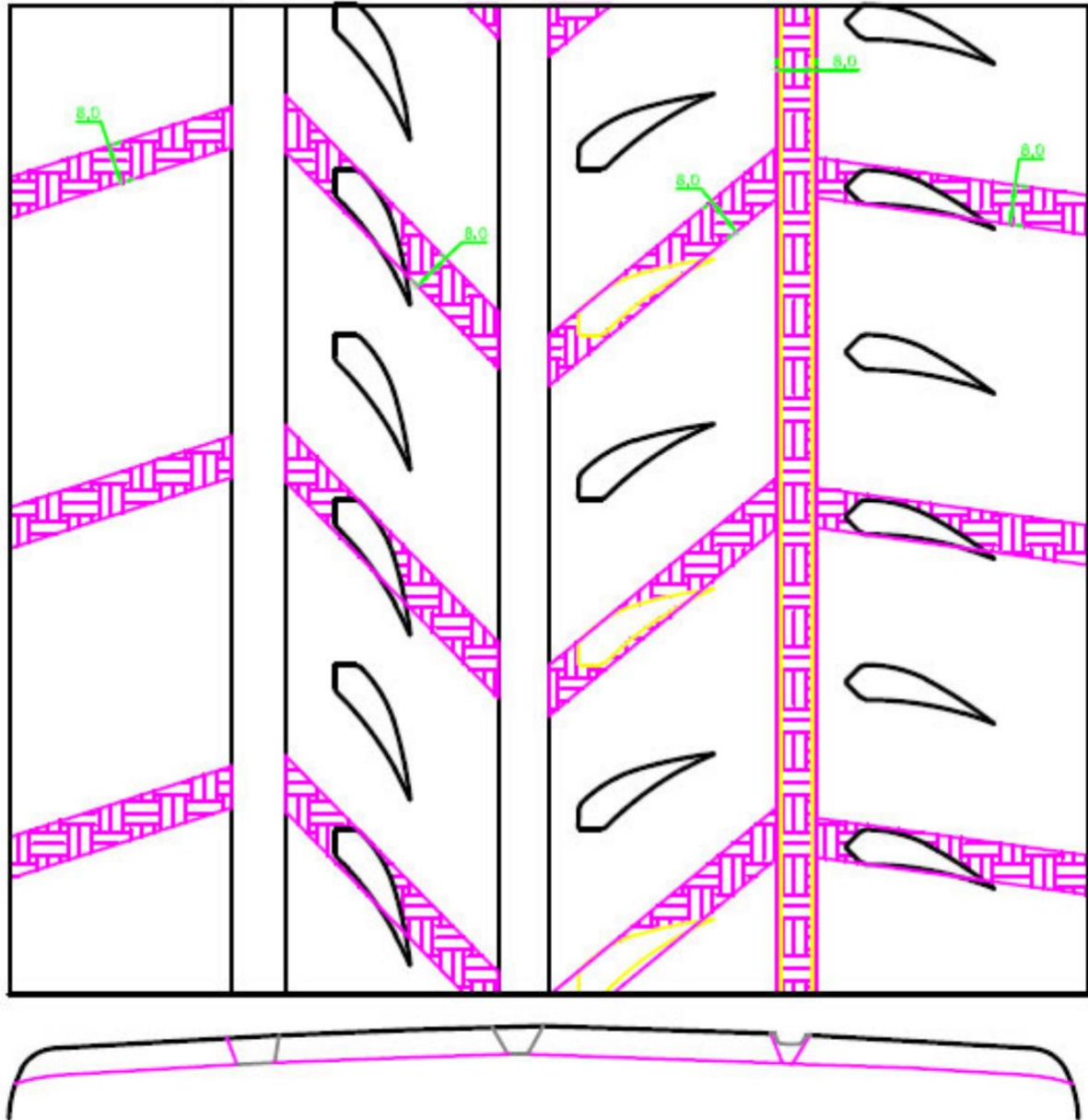

DMT RC22

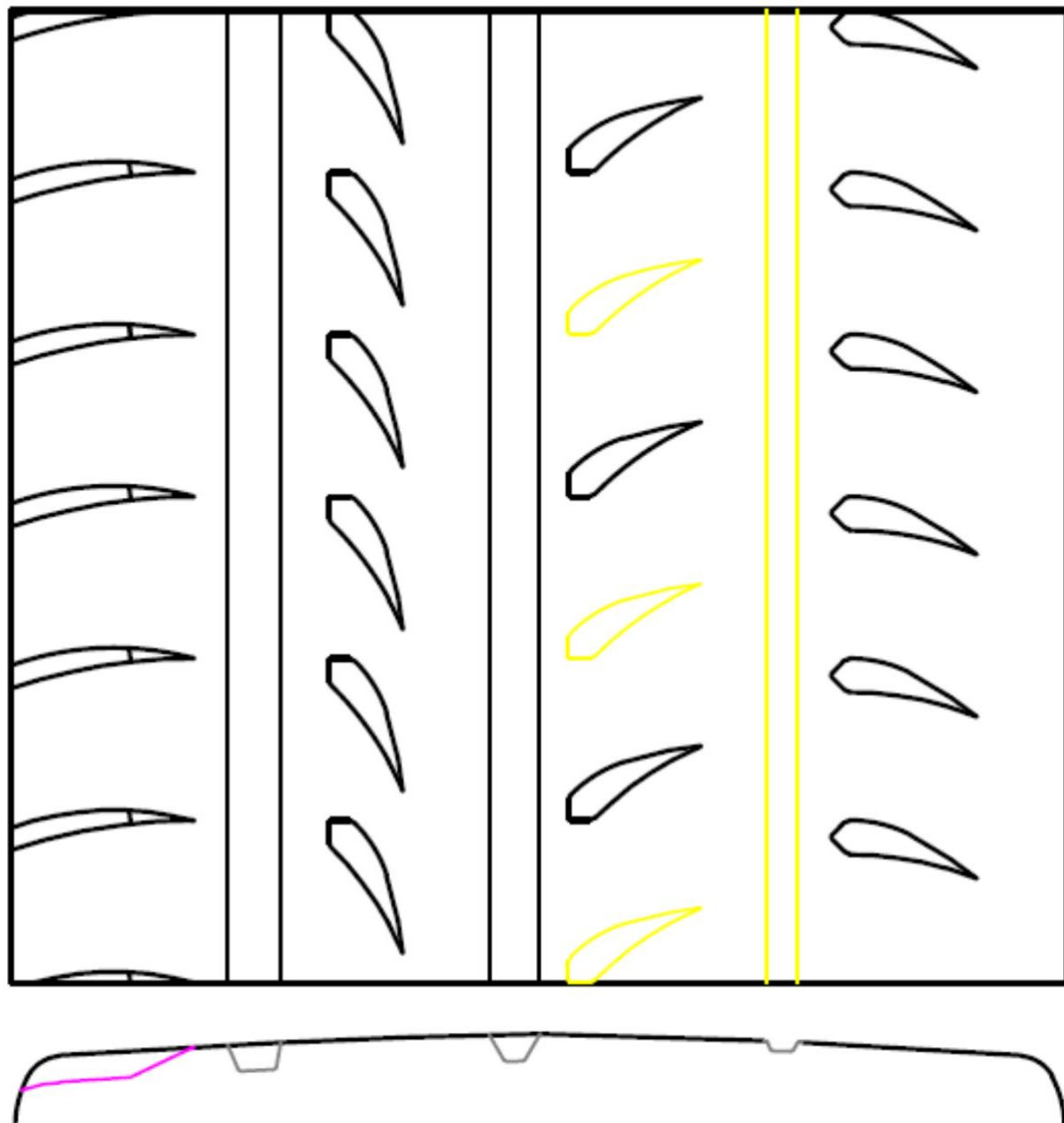

DMT RC22 Wet Cut

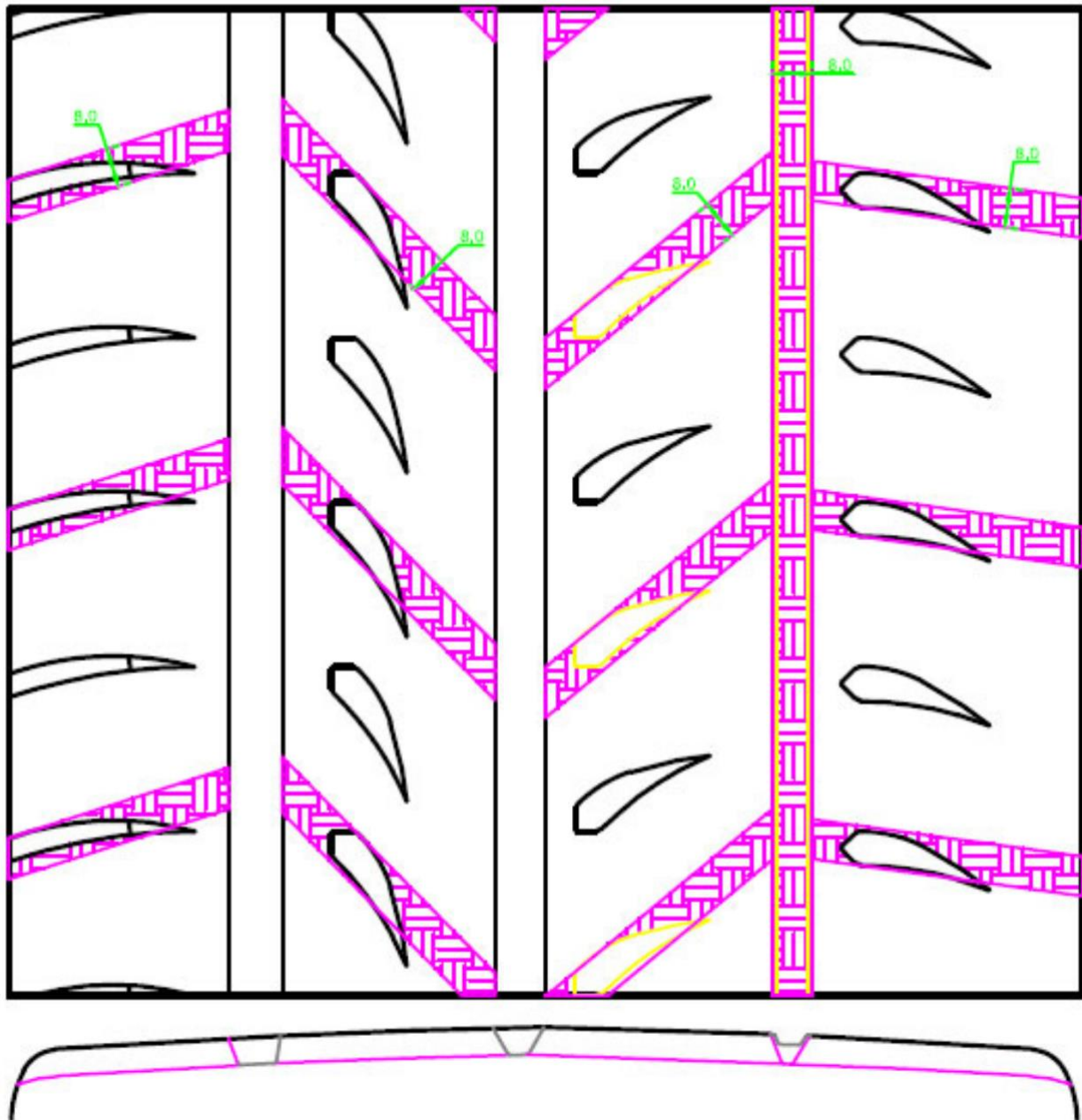



MRF



195/50 R15 Tarmac Rally - Hand Cut Pattern for Wet

Dry Pattern
Groove Ratio > 17%

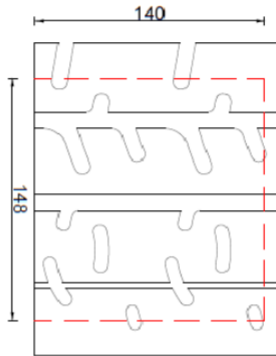

Light Rain
Groove Ratio > 27.5%

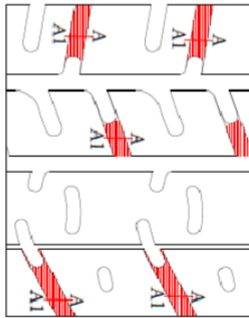

Heavy Rain
Groove Ratio > 32.5%

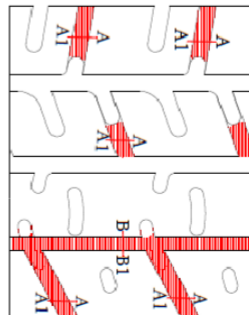

Control area 148 x 140 mm (Dotted Line)

SECTION: A-A1

SECTION: B-B1

A-A1 - 10 mm
B-B1 - 8 mm

Hand Cut Groove Portion

CLASS 8"
RIM 6.5"

<p>CLASS 8" RIM 6.5"</p>	
<p>ISSUES ZTA T - HAND CUT-WET PATTERN</p>	
<p>REV. 01</p>	<p>DATE: 15/03/2024</p>
<p>REV. 02</p>	<p>DATE: 15/03/2024</p>
<p>REV. 03</p>	<p>DATE: 15/03/2024</p>
<p>REV. 04</p>	<p>DATE: 15/03/2024</p>
<p>REV. 05</p>	<p>DATE: 15/03/2024</p>
<p>REV. 06</p>	<p>DATE: 15/03/2024</p>
<p>REV. 07</p>	<p>DATE: 15/03/2024</p>
<p>REV. 08</p>	<p>DATE: 15/03/2024</p>
<p>REV. 09</p>	<p>DATE: 15/03/2024</p>
<p>REV. 10</p>	<p>DATE: 15/03/2024</p>
<p>REV. 11</p>	<p>DATE: 15/03/2024</p>
<p>REV. 12</p>	<p>DATE: 15/03/2024</p>
<p>REV. 13</p>	<p>DATE: 15/03/2024</p>
<p>REV. 14</p>	<p>DATE: 15/03/2024</p>
<p>REV. 15</p>	<p>DATE: 15/03/2024</p>
<p>REV. 16</p>	<p>DATE: 15/03/2024</p>
<p>REV. 17</p>	<p>DATE: 15/03/2024</p>
<p>REV. 18</p>	<p>DATE: 15/03/2024</p>
<p>REV. 19</p>	<p>DATE: 15/03/2024</p>
<p>REV. 20</p>	<p>DATE: 15/03/2024</p>
<p>REV. 21</p>	<p>DATE: 15/03/2024</p>
<p>REV. 22</p>	<p>DATE: 15/03/2024</p>
<p>REV. 23</p>	<p>DATE: 15/03/2024</p>
<p>REV. 24</p>	<p>DATE: 15/03/2024</p>
<p>REV. 25</p>	<p>DATE: 15/03/2024</p>
<p>REV. 26</p>	<p>DATE: 15/03/2024</p>
<p>REV. 27</p>	<p>DATE: 15/03/2024</p>
<p>REV. 28</p>	<p>DATE: 15/03/2024</p>
<p>REV. 29</p>	<p>DATE: 15/03/2024</p>
<p>REV. 30</p>	<p>DATE: 15/03/2024</p>
<p>REV. 31</p>	<p>DATE: 15/03/2024</p>
<p>REV. 32</p>	<p>DATE: 15/03/2024</p>
<p>REV. 33</p>	<p>DATE: 15/03/2024</p>
<p>REV. 34</p>	<p>DATE: 15/03/2024</p>
<p>REV. 35</p>	<p>DATE: 15/03/2024</p>
<p>REV. 36</p>	<p>DATE: 15/03/2024</p>
<p>REV. 37</p>	<p>DATE: 15/03/2024</p>
<p>REV. 38</p>	<p>DATE: 15/03/2024</p>
<p>REV. 39</p>	<p>DATE: 15/03/2024</p>
<p>REV. 40</p>	<p>DATE: 15/03/2024</p>
<p>REV. 41</p>	<p>DATE: 15/03/2024</p>
<p>REV. 42</p>	<p>DATE: 15/03/2024</p>
<p>REV. 43</p>	<p>DATE: 15/03/2024</p>
<p>REV. 44</p>	<p>DATE: 15/03/2024</p>
<p>REV. 45</p>	<p>DATE: 15/03/2024</p>
<p>REV. 46</p>	<p>DATE: 15/03/2024</p>
<p>REV. 47</p>	<p>DATE: 15/03/2024</p>
<p>REV. 48</p>	<p>DATE: 15/03/2024</p>
<p>REV. 49</p>	<p>DATE: 15/03/2024</p>
<p>REV. 50</p>	<p>DATE: 15/03/2024</p>



MRF



195/50 R16 Tarmac Rally - Hand Cut Pattern for Wet

Dry Pattern
Groove Ratio > 17%

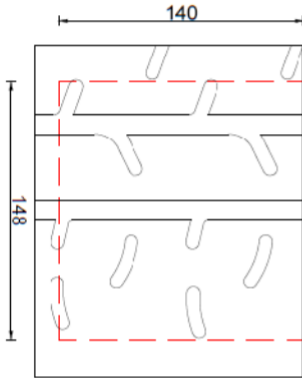

Light Rain
Groove Ratio > 27.5%

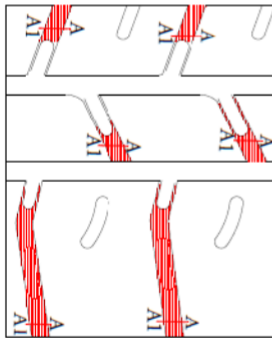

Heavy Rain
Groove Ratio > 32.5%

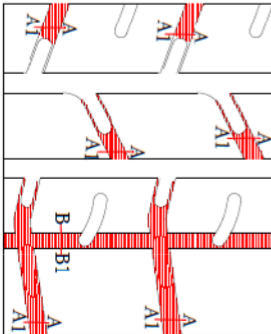

Control area 148 x 140 mm (Dotted Line)

SECTION: A-A1

SECTION: B-B1

A-A1 - 10 mm
B-B1 - 8 mm

 Hand Cut Groove Portion

CLASS 8"
RIM 6.5"

NO.	DESCRIPTION	QTY	UNIT
1	195/50R16 STA TL-HAND CUT WET PATTERN	1	EA



MRF



235/40 R18 Tarmac Rally - Hand Cut Pattern for Wet

Dry Pattern
Groove Ratio > 17%

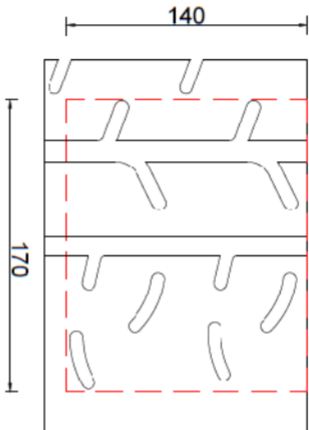

Light Rain
Groove Ratio > 27.5%

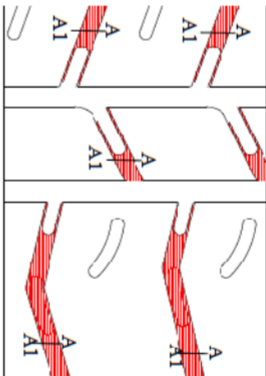

Heavy Rain
Groove Ratio > 32.5%

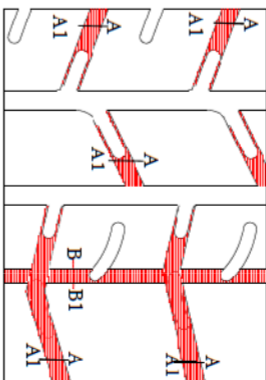

Control area 170 x 140 mm (Dotted Line)

SECTION: A-A1

SECTION: B-B1

A-A1 - 10 mm
B-B1 - 8 mm
Hand Cut Groove Portion

CLASS 9"
RIM 8.0"

ITEM NO.	DESCRIPTION	QUANTITY	UNIT
1	MRF 235/40 R18 Tarmac Rally - Hand Cut Wet Pattern	1	EA
<p>CLASS 9" RIM 8.0"</p>			
<p>235/40R18 ZTA - T - HAND CUT WET PATTERN</p>			
<p>1 A-0018</p>			



Category : GT Asphalt Rally
Dimension : 24 / 65 – 18 TL PILOT SPORT R
Cutting plan of Pilot Sport R tread pattern for RGT

Clermont-Ferrand the 20/05/2020

cuts (red parts) with Blade R2



Extérieur véhicule

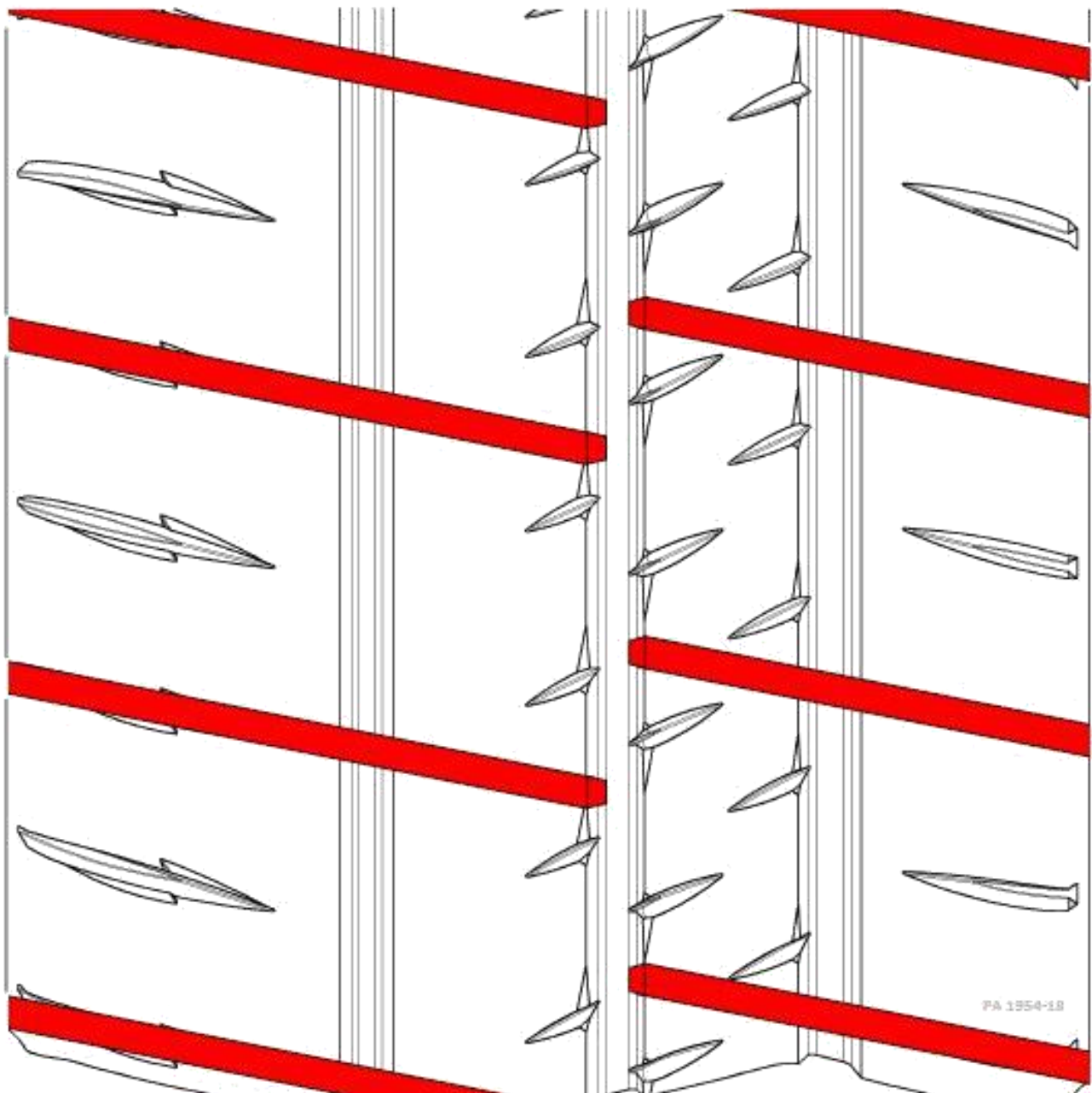

PA 1354-18



Catégorie : GT Asphalt Rally
Dimension : 29 / 65 – 18 TL PILOT SPORT R
Cutting plan of Pilot Sport R tread pattern for RGT

Clermont-Ferrand the 20/05/2020



Extérieur véhicule

Intérieur véhicule

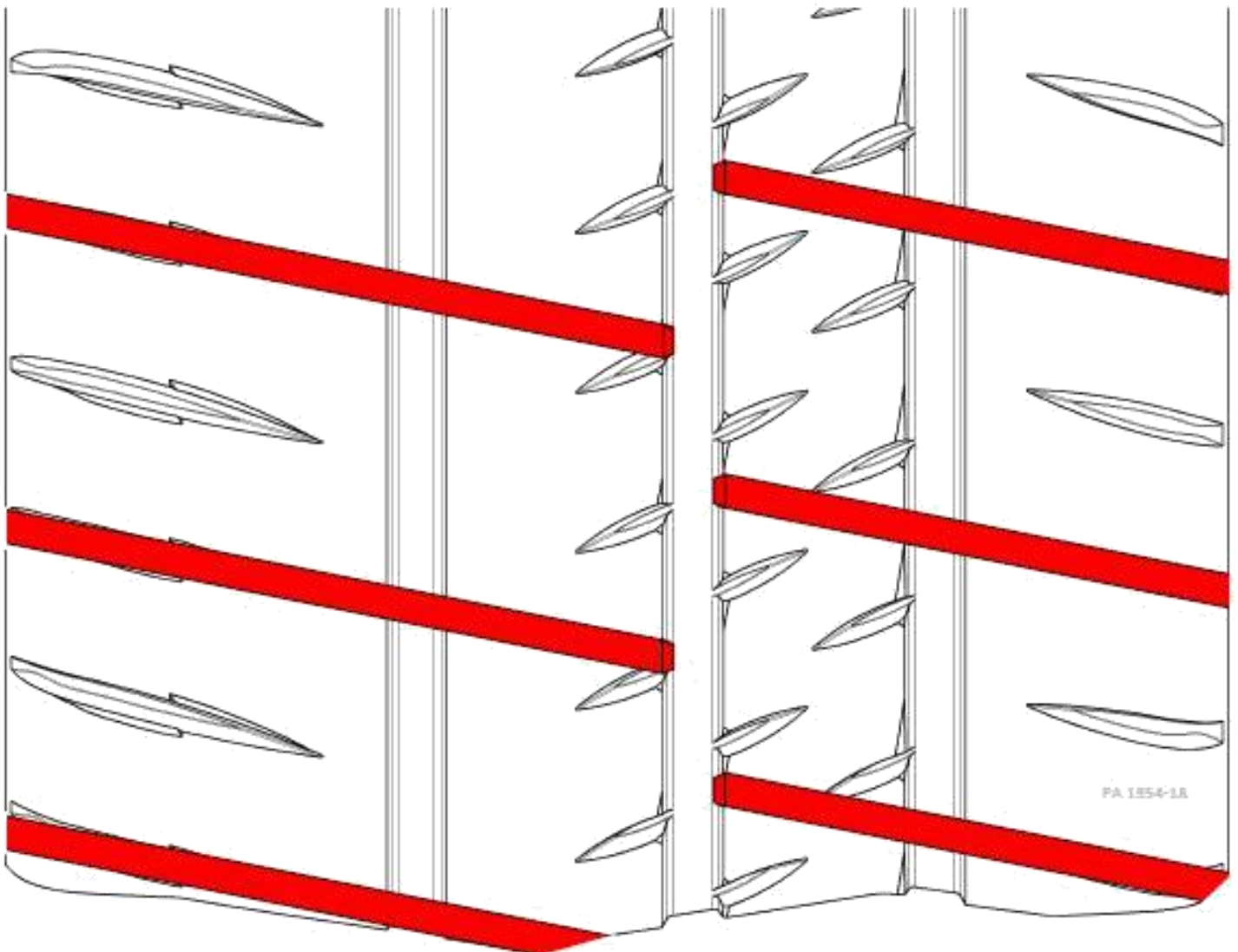



Category : Asphalt Rally

Clermont-Ferrand the 20/05/2020

Dimensions : 20/65-18, 20/63/17, 19/63-17, 19/60-16, 20/58-15, 19/58-15, 16/57-14

Cutting plan of Pilot Sport R tread pattern

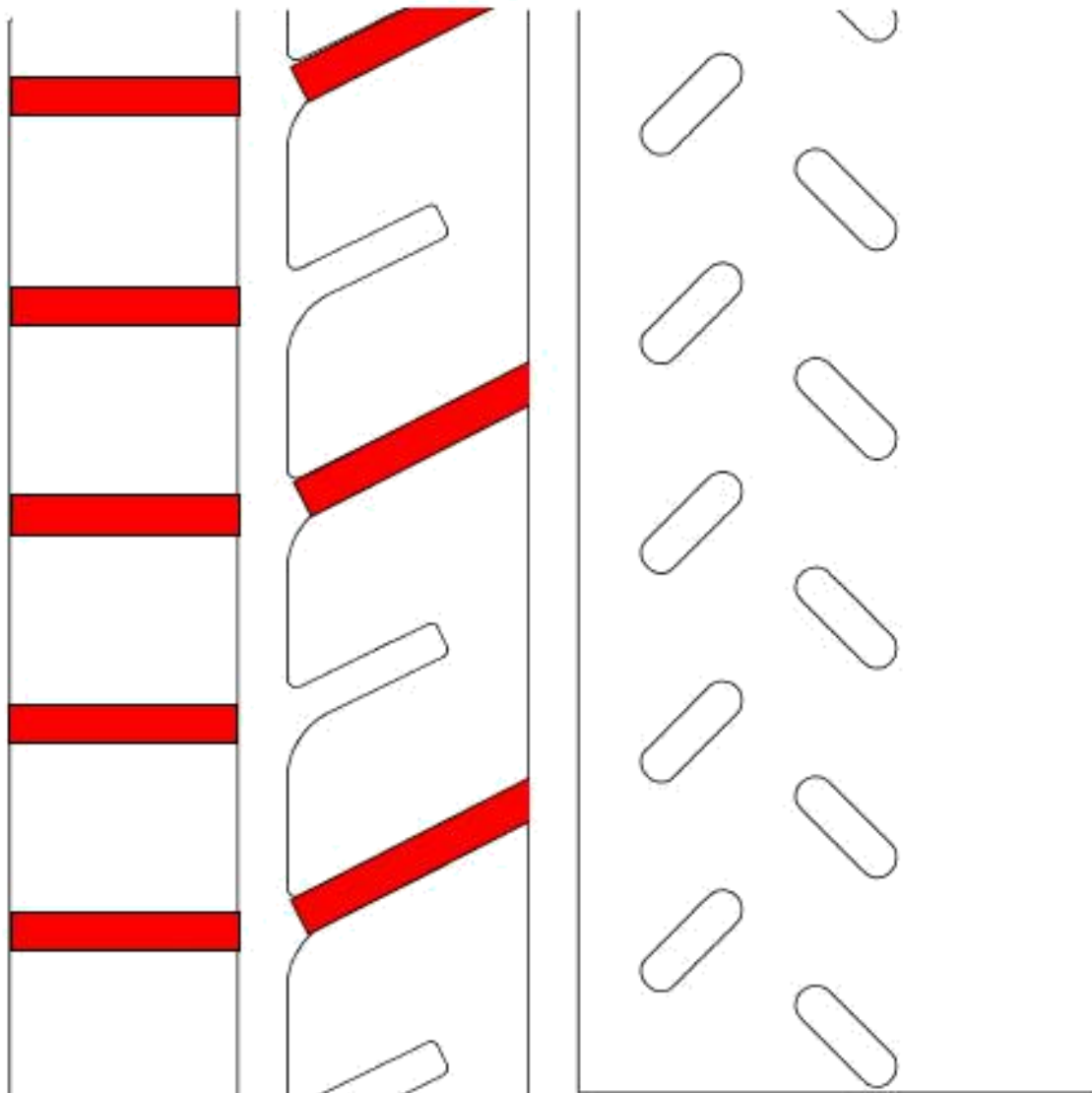

NEW 2023

MICHELIN 19/60-16 & 19/63-17 TL PILOT SPORT PRO ^{RALLY} hand cut pattern
Clermont-Ferrand the 02/19/2023

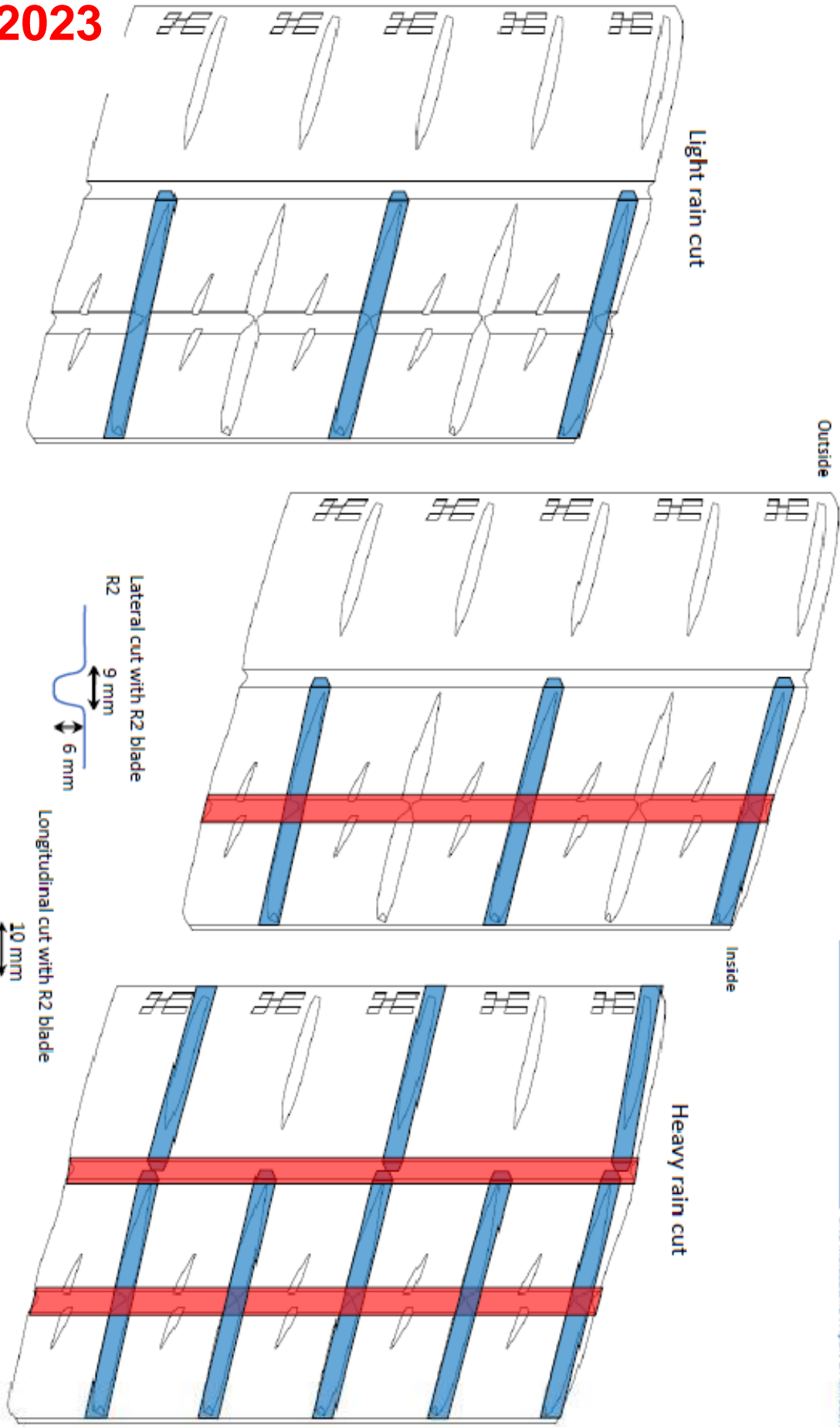

MICHELIN 20/65-18 TL PILOT SPORT A hand cut pattern

Clermont-Ferrand the 02/19/2023

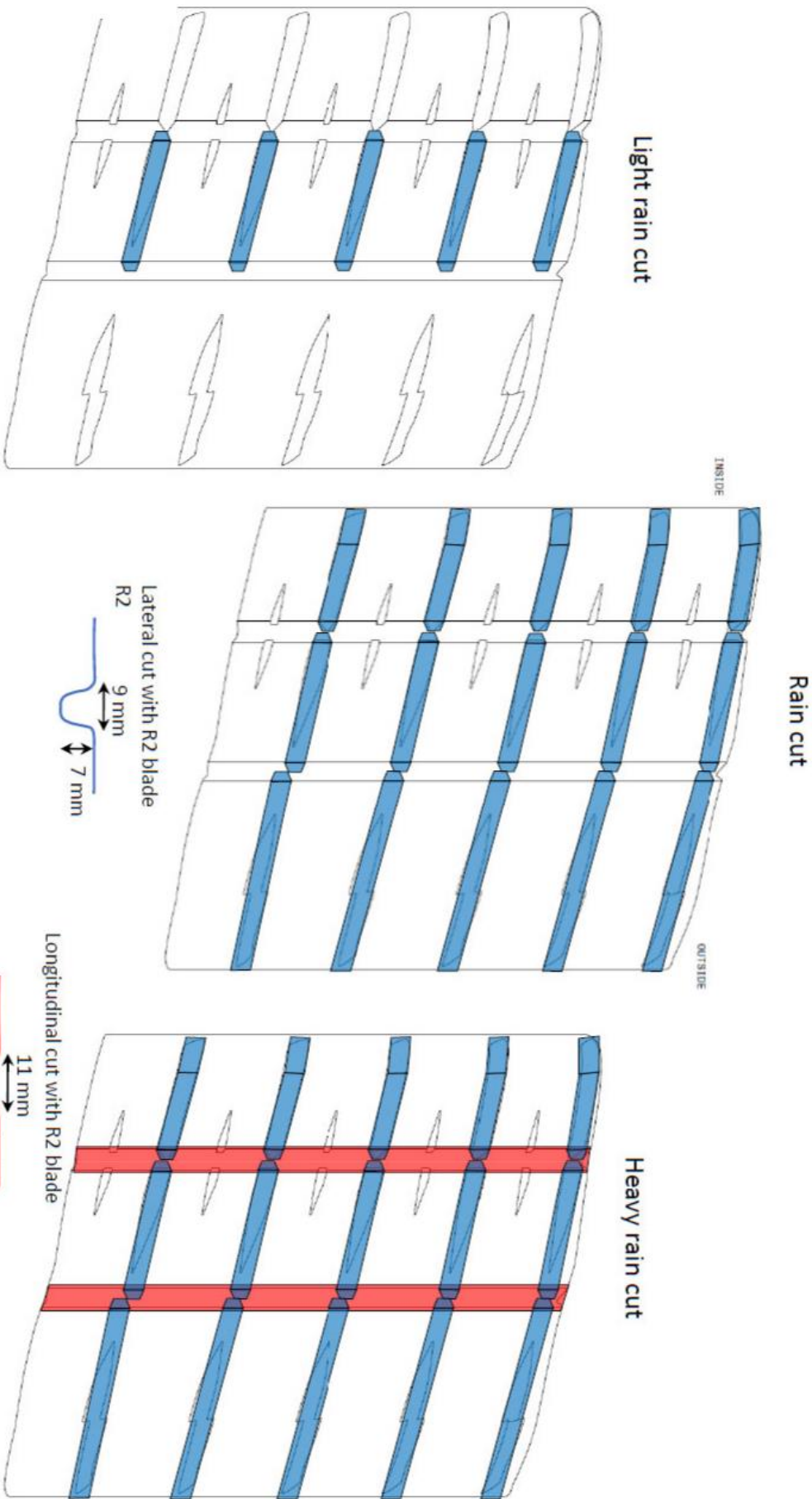



235/40R18 PZERO RA
205/45R17 PZERO RA
195/50R16 PZERO RA

Cut 1 for Damp conditions



W = 6 mm
D = 6 mm
Blade R2

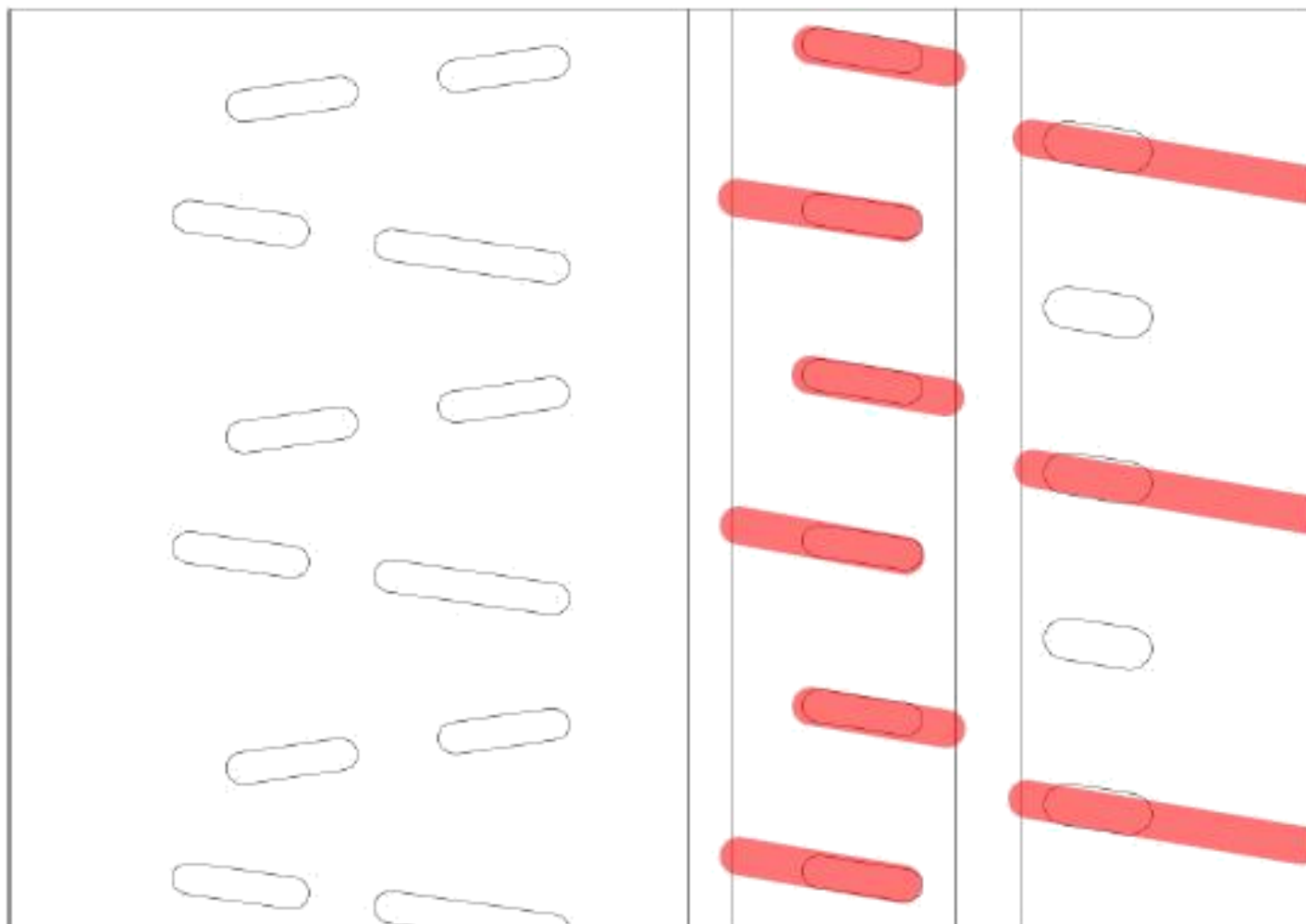



235/40R18 PZERO RA
205/45R17 PZERO RA
195/50R16 PZERO RA

Cut 3 for Wet conditions



W = 6 mm
D = 6 mm
Blade R2

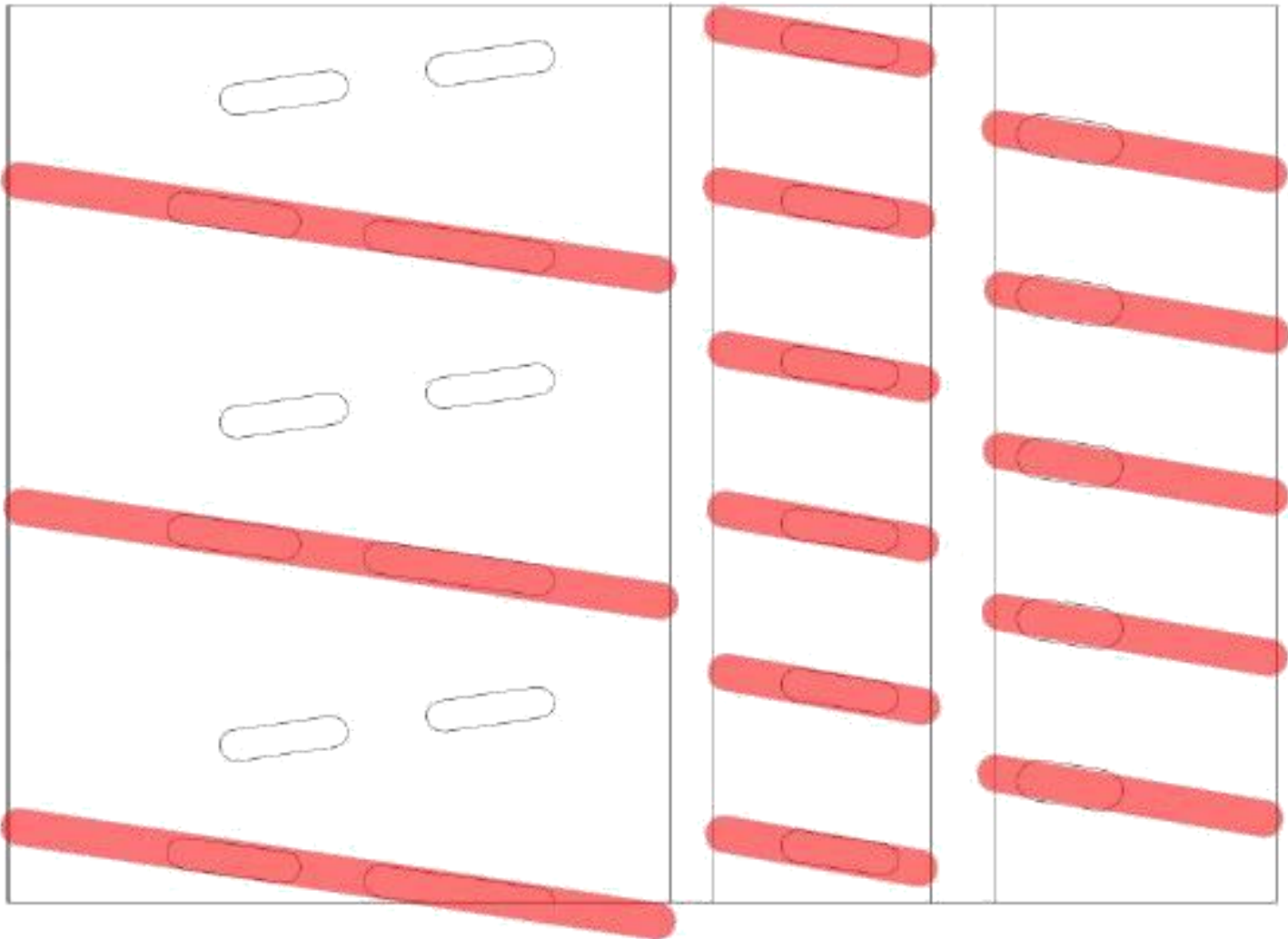



235/40R18 CINTURATO RW
205/45R17 CINTURATO RW
195/50R16 CINTURATO RW

Cut 4 for Wet conditions with standing water on the stage



W = 8 mm
D = 7 mm
Blade W4



W = 6mm
D = 7mm
Blade R3

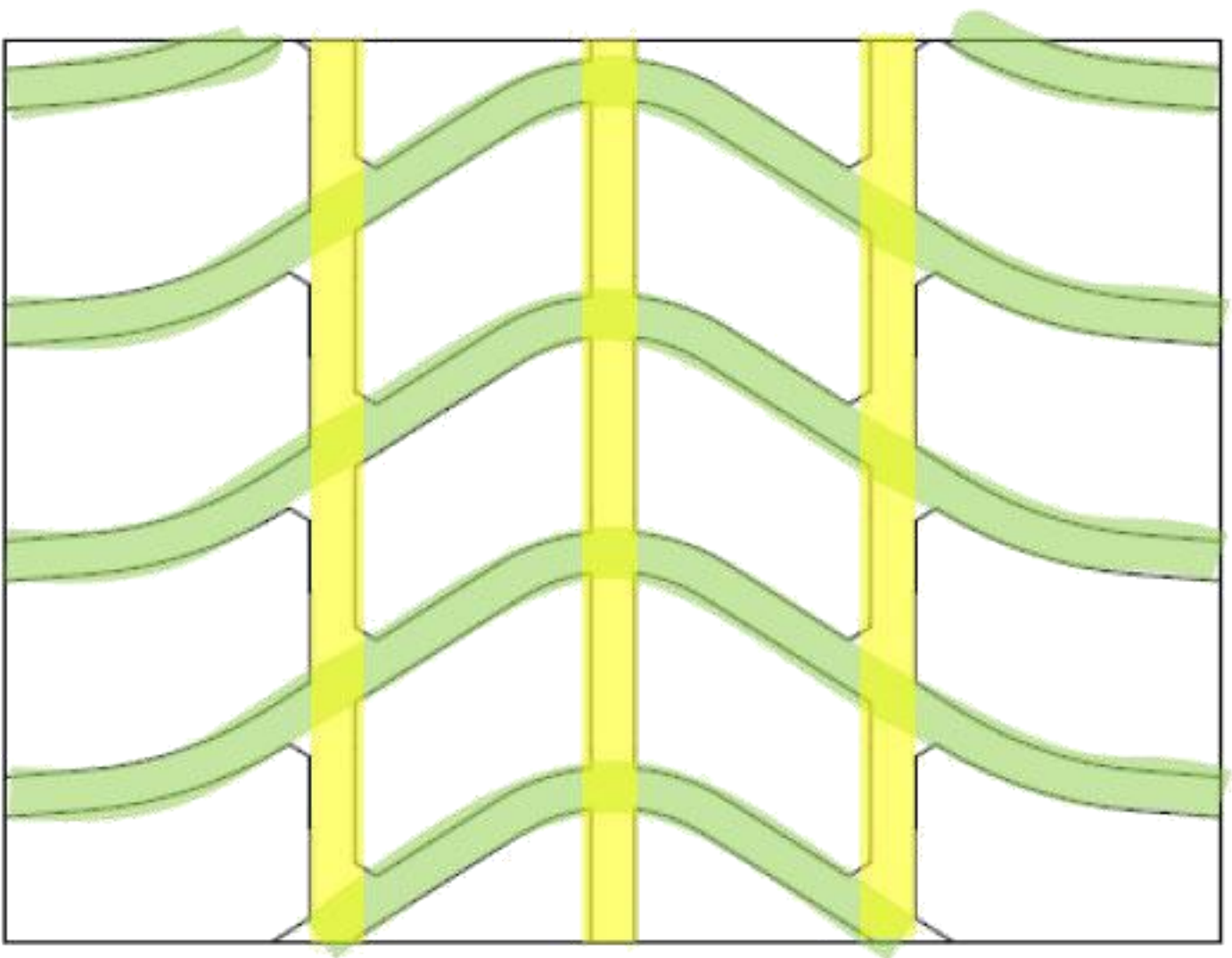



Tarmac Rally tire hand cut pattern for wet

(Cut red marked area)

195/50R13 (200/530R13), 225/45R13 (220/530R13),
195/50R15, 225/45R15

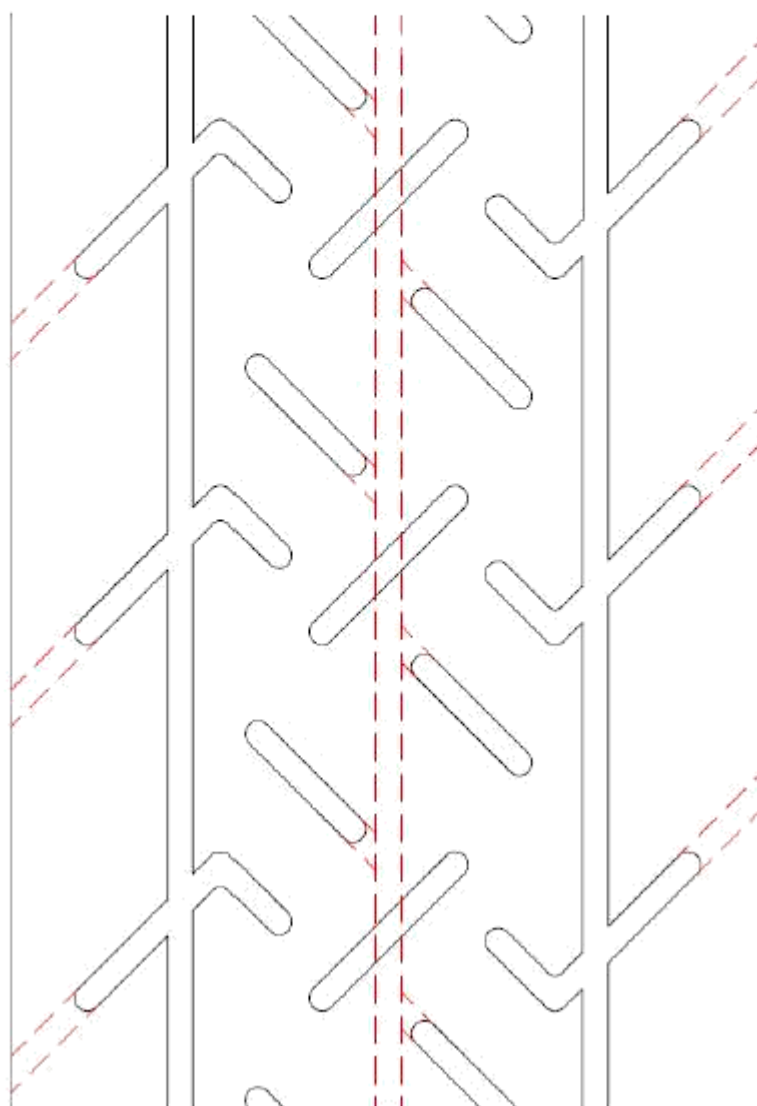



Tarmac Rally tire hand cut pattern for wet
(Cut red marked area)
195/50R16, 195/50R17, 225/40R18

Light Rain

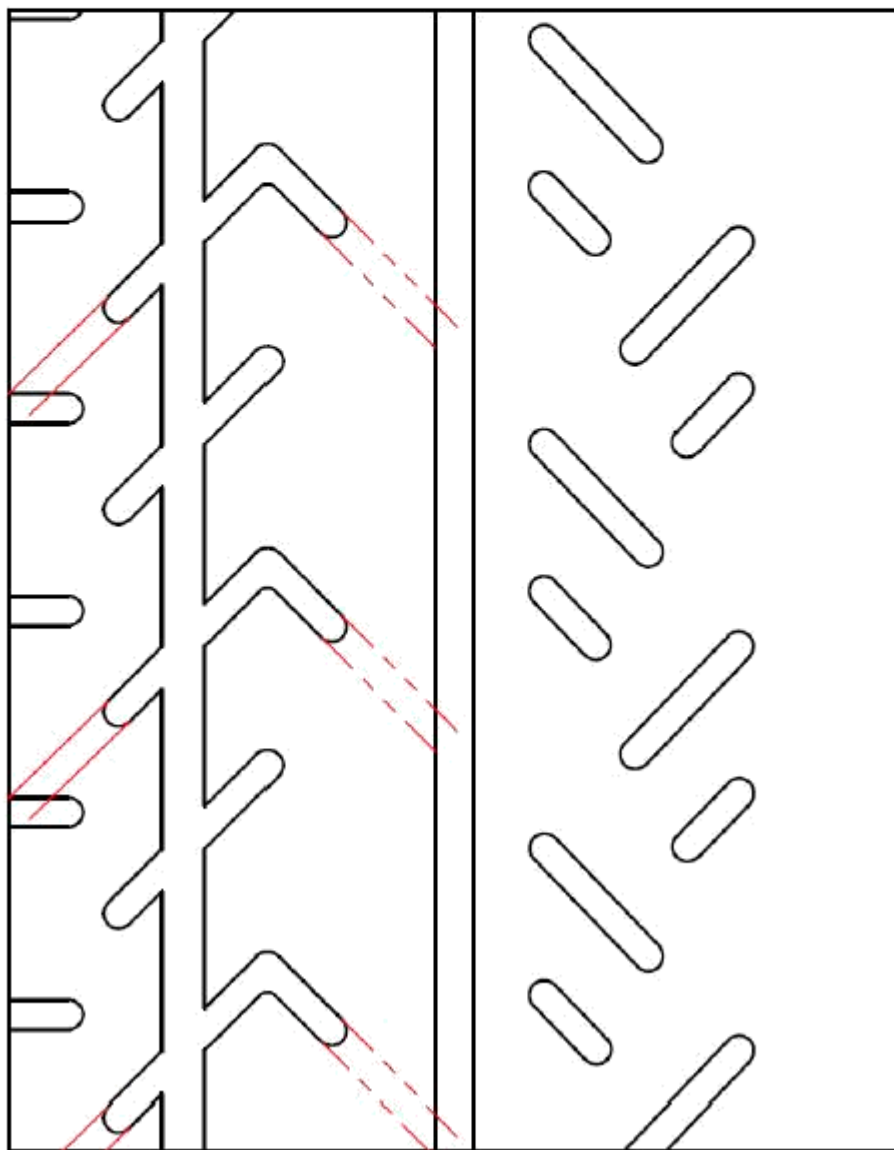



Tarmac Rally tire hand cut pattern for wet

(Cut red marked area)

195/50R16, 195/50R17, 225/40R18

Medium Rain

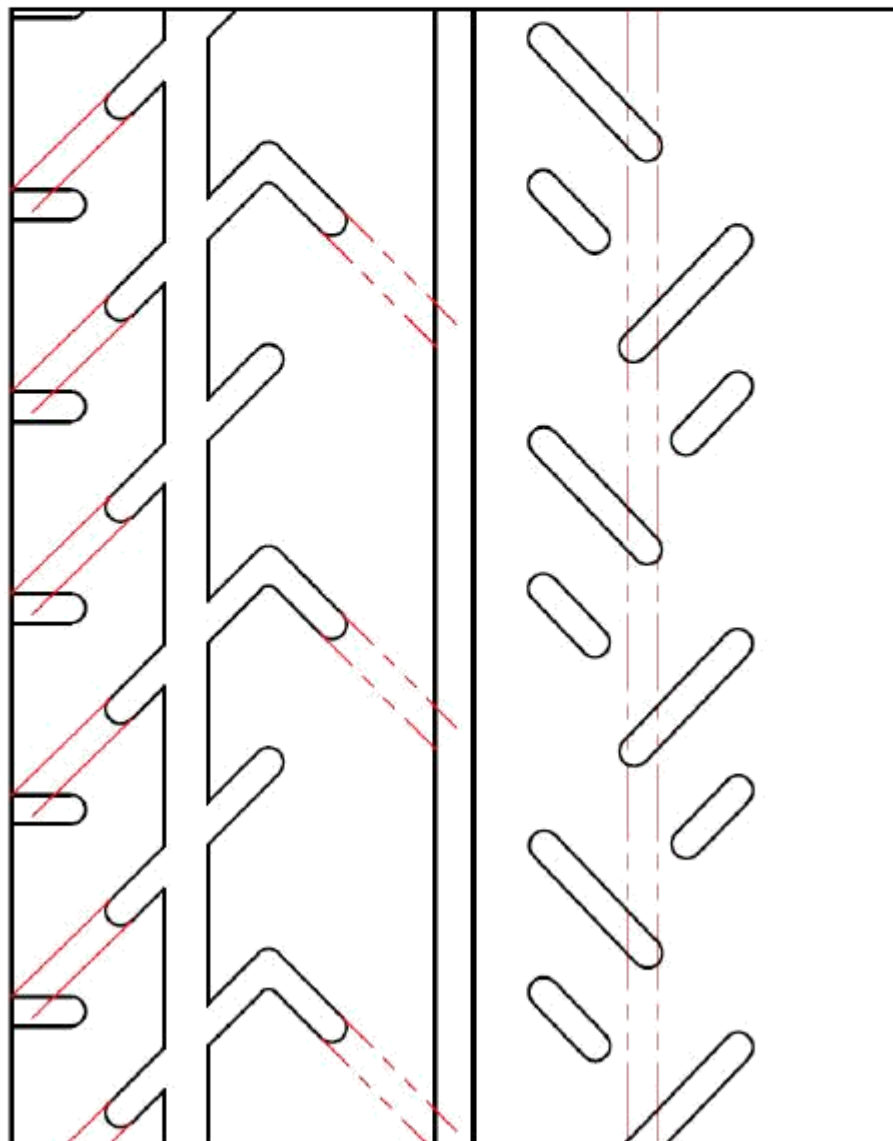



Tarmac Rally tire hand cut pattern for wet

(Cut red marked area)

195/50R16, 195/50R17, 225/40R18

Heavy Rain

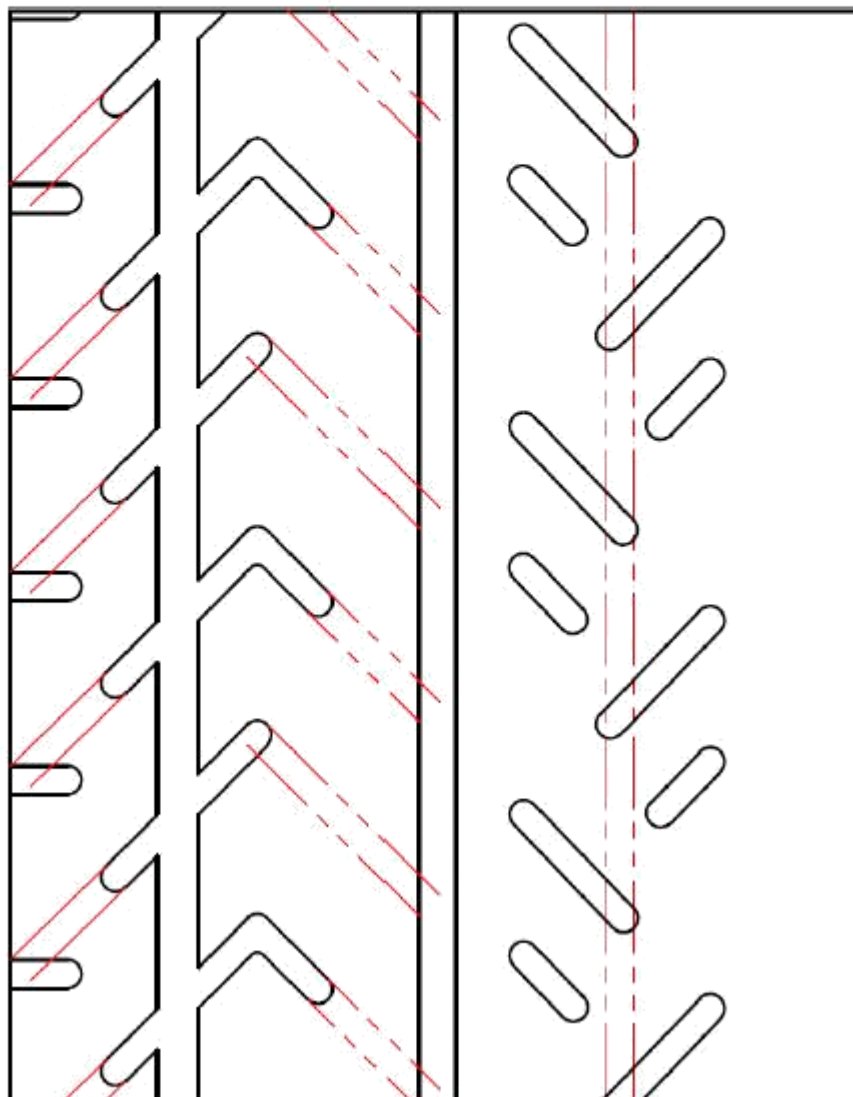



EXTREME VRC 27/66-18

Hand-cut pattern: damp

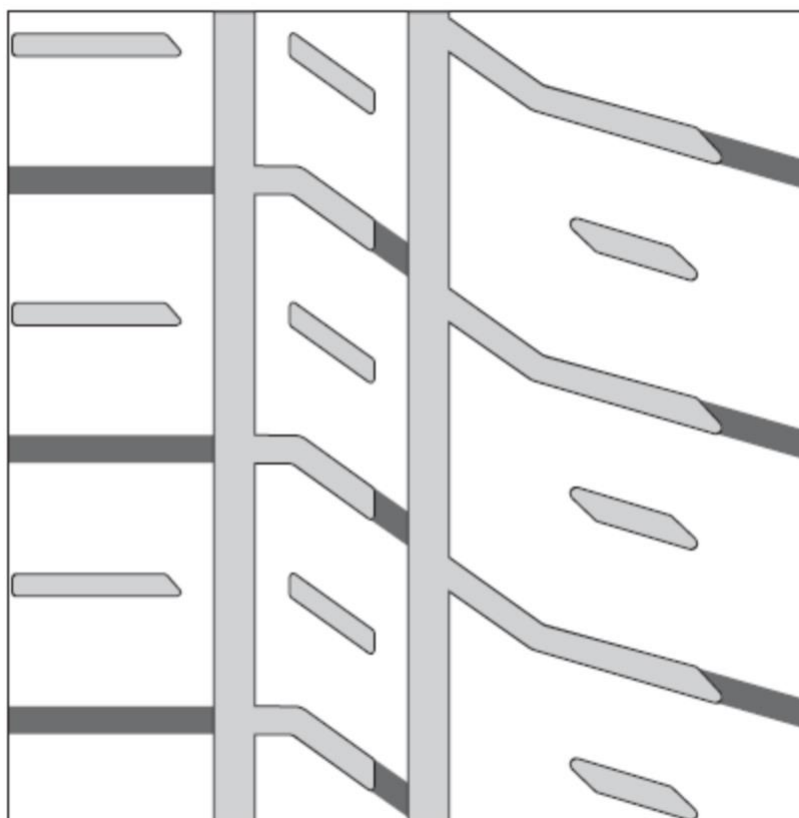



 groove: 9mm width; 6,5mm depth

Scale: 1:2

EXTREME VRC 27/66-18

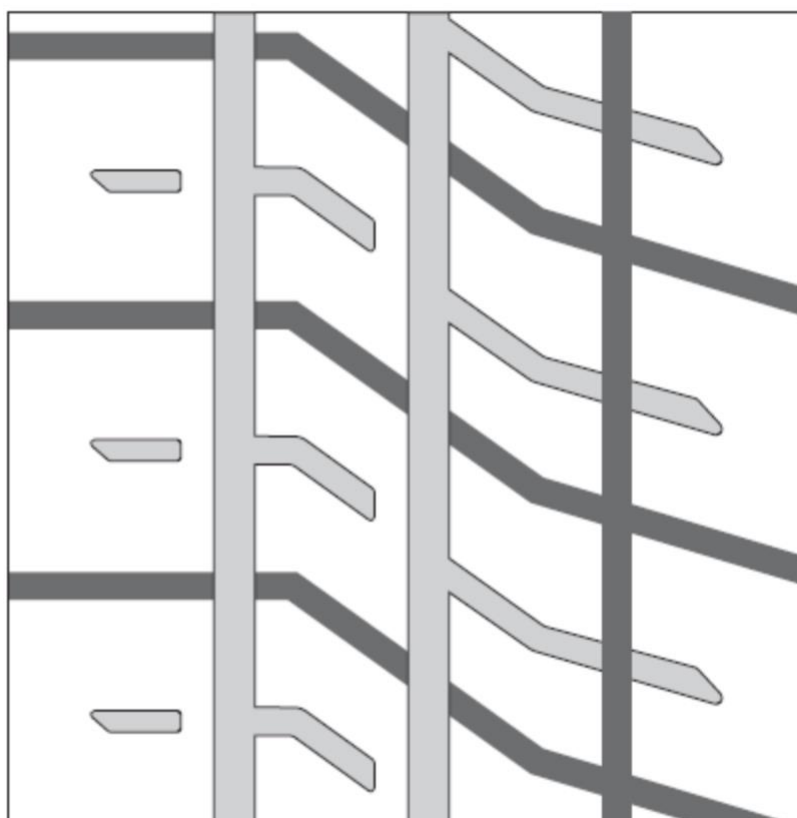
Hand-cut pattern: extra wet



 groove: 9mm width; 6,5mm depth

Scale: 1:2



RAIN CUT

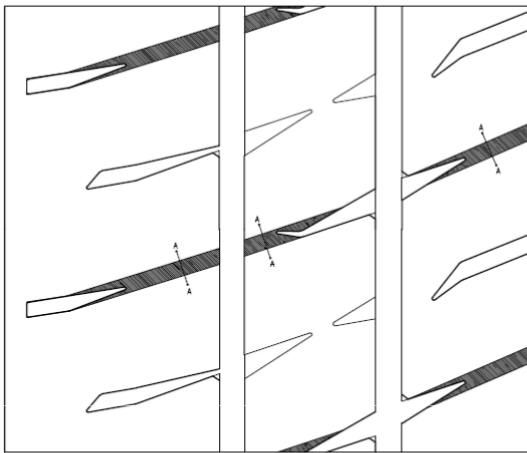

HEAVY RAIN CUT

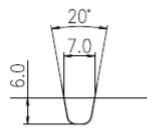
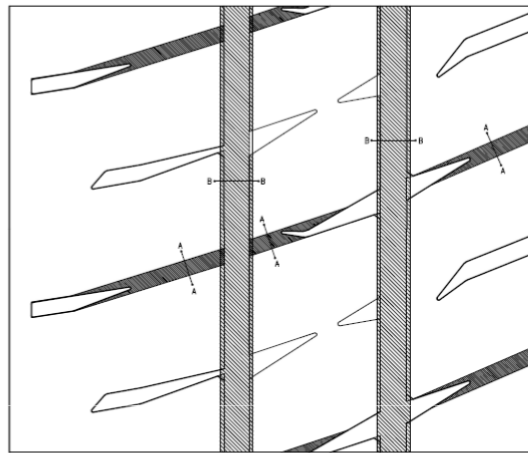

A-A

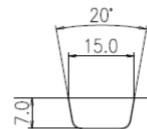

B-B

CUT WET PATTERN	 SUMITOMO RUBBER INDUSTRIES,LTD. MOTOR SPORTS DEPARTMENT	Size • Pattern
		210/650R18
		190/625R17
		DIREZZA 301R

HANKOOK Ventus Z215 Recut guide Sizes:

210/650R18, 190/630R17, 190/600R16

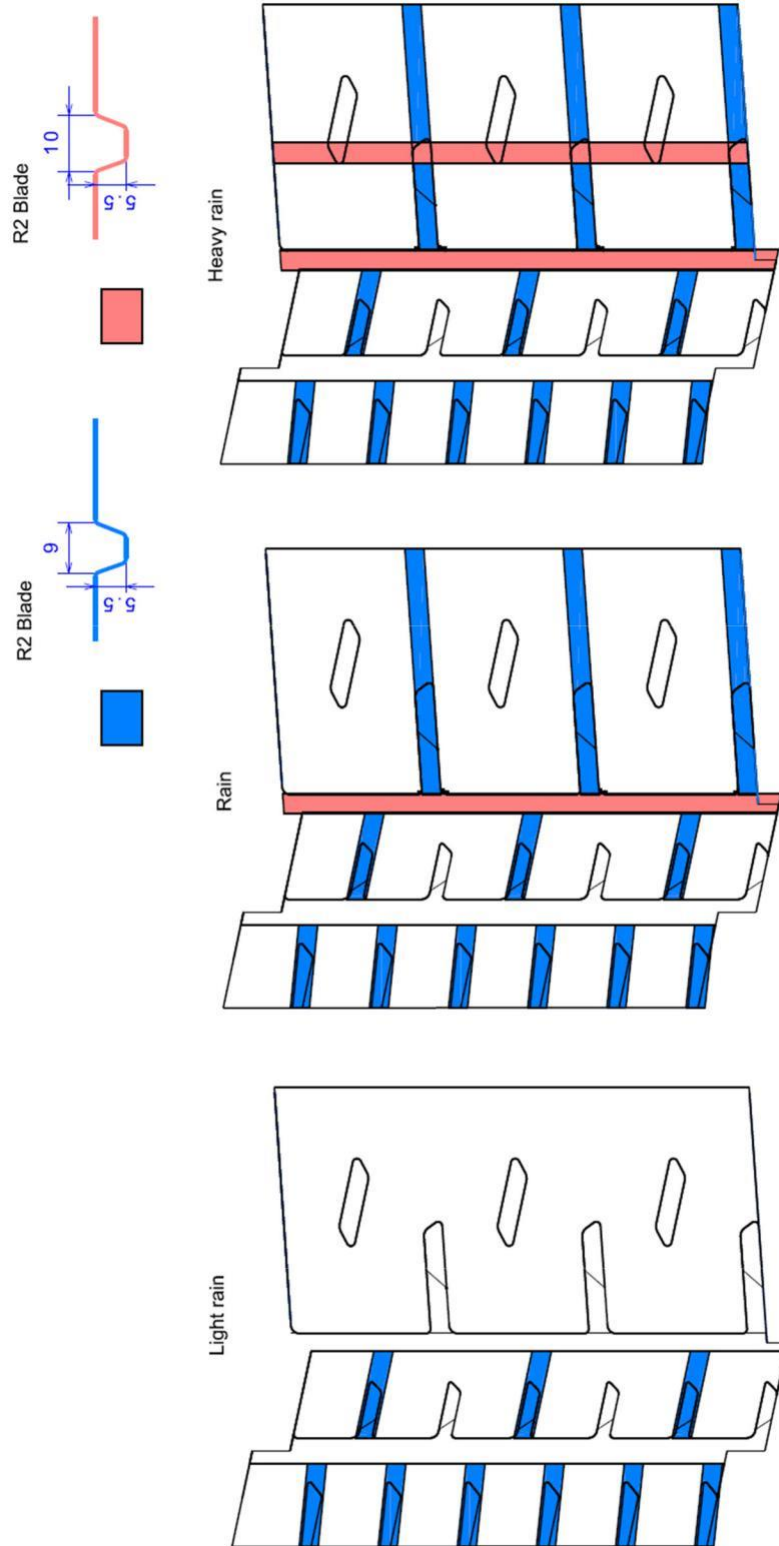

HANKOOK Ventus Z205 Recut guide

Sizes: 210/650R18, 210/625R17, 180/625R17, 180/600R16, 200/580R15, 190/580R15, 170/560R14

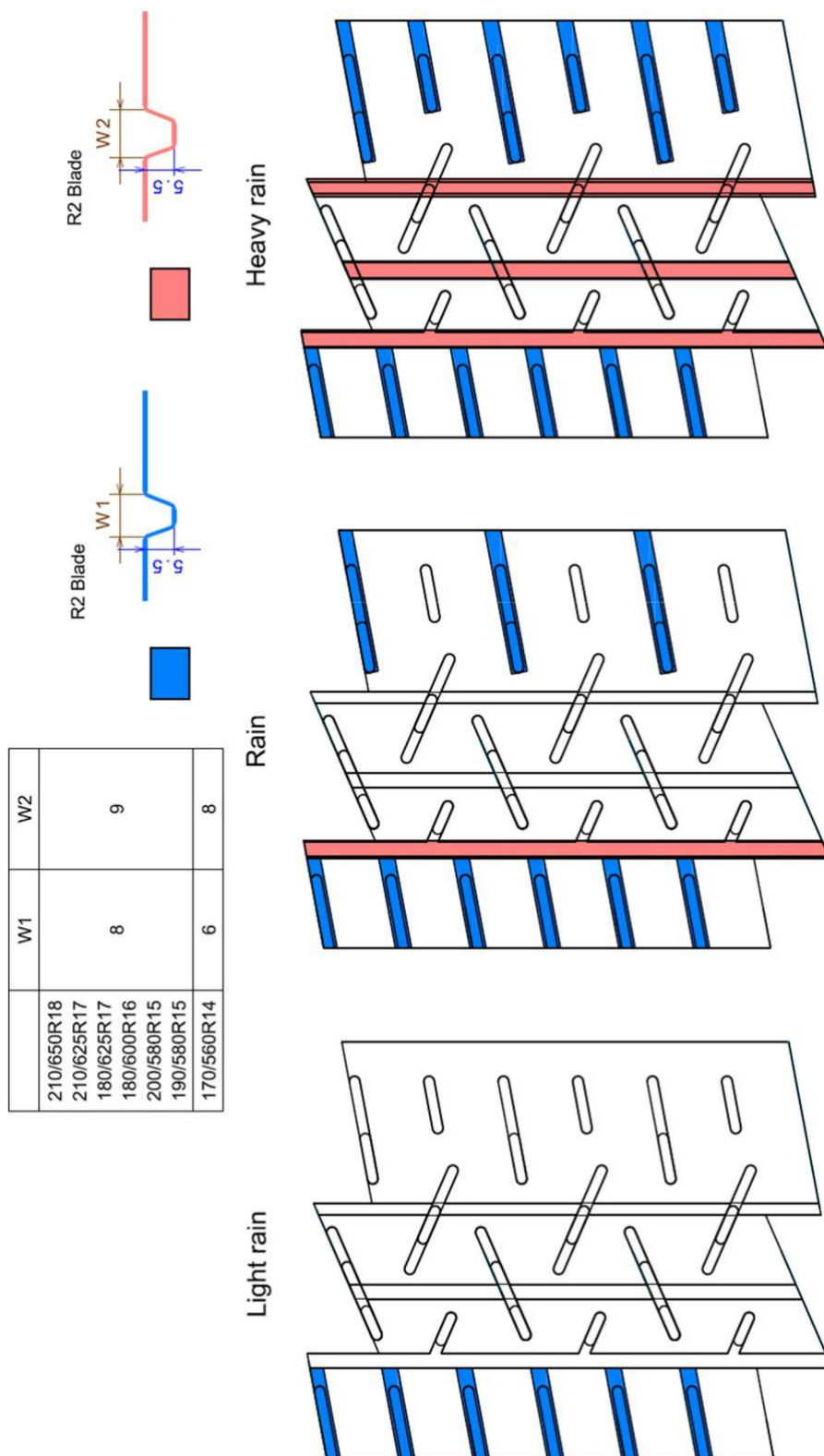



KUMHO TYRES

Moulded tyre for FIA homologation

Size : 210/645R18

Pattern : TM02

18"-210/645R18

17"-190/630R17

16"-190/600R16

15"-180/580R15

On the basis of a tread pattern width of 170mm and circumference of 140mm

- The surface taken up by grooves at least 5.5 mm deep, with a maximum angle of 60° between the block in section and 2mm wide, must occupy at least 17% of the total surface.
- The surface taken up by grooves at least 1.8 mm deep, with a maximum angle of 60° between the block in section and 2mm wide, must occupy at least 21.5% of the total surface.
- The sum of the width of the grooves encountered by a radial line must be at least 16mm
- At least 2 circumferential lines / Minimum total width of circumferential lines at least 12mm

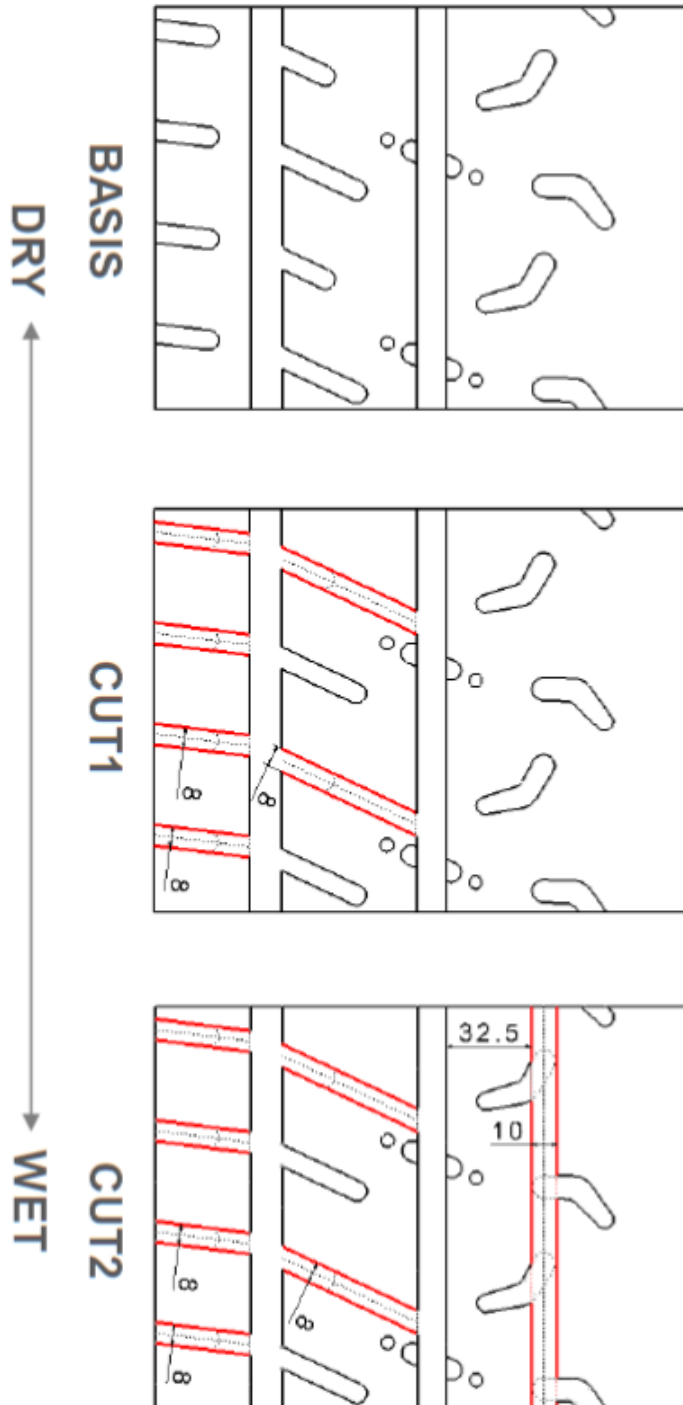

ATUALIZAÇÕES

Art. / Data	Estado	Art. / Data	Estado	Art. / Data	Estado
Pág. 35 / 09.10	Novo				